

Please read through this User's Manual before use for correct handling.
Please keep this User's Manual for future reference.

CAUTIONARY NOTES FOR SAFE USE OF THE PRODUCT

This User's Manual should be carefully read before installing and operating the product. The following symbol is used on the product and in this manual to ensure safe use.



This symbol is displayed on the product when it is necessary to refer to the User's Manual for information on personnel and instrument safety. This symbol is displayed in the User's Manual to indicate precautions for avoiding danger to the operator, such as an electric shock.

The following symbols are used only in this manual.



IMPORTANT

Indicates that operating the hardware or software in a particular manner may cause damage or result in a system failure.



NOTE

Draws attention to essential information for understanding the operations and/or functions of the product.

CHECKING PRODUCT SPECIFICATIONS AND PACKAGED ITEMS

(1) Checking the Model and Product Specifications

Check that the model and specifications indicated on the nameplate attached to the main unit are as ordered.

(2) Packaged Items

Check that the package contains the following items:

- MS5D: 1
- Spacer (for DIN rail mounting): 1
- Range label: 1
- User's Manual (this manual: IM 77J04S05-02E): 1

GENERAL

The MS5D is a plug-in type potentiometer converter that is used in combination with an instrument to transmit information for displacement of valve etc. by resistance change of potentiometer. It converts the resistance changes into isolated DC current or DC voltage signals.

MODEL AND SUFFIX CODES

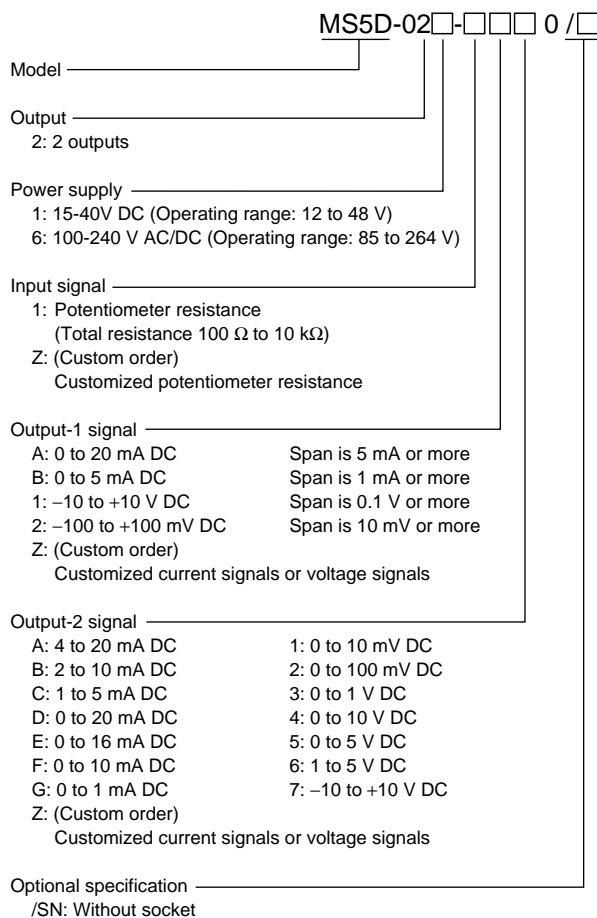

1. MOUNTING METHOD



NOTE

Plug/disconnect the main unit into/from the socket vertically to the socket face. Otherwise the terminals may bend and it may cause bad contact.

1.1 Wall Mounting

Unfasten the upper and lower stoppers of the converter to disconnect the main unit from the socket. Next, anchor the socket onto the wall with two M4 screws. Then, plug the main unit into the socket and secure the main unit with the upper and lower stoppers.

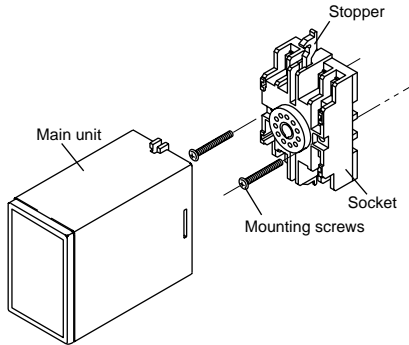

[Mounting Dimensions]

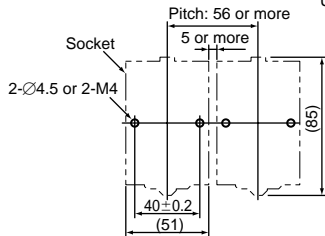

Unit: mm

Note:

- When mounting the units close together, leave a space of at least 5 mm between them.
- Use the supplied spacer to keep a space of 5 mm for DIN rail mounting.

1.2 DIN Rail Mounting

Locate the converter so that the DIN rail fits into the upper part of the DIN-rail groove at the rear of the socket, and fasten the socket using the slide lock at the lower part of the socket.

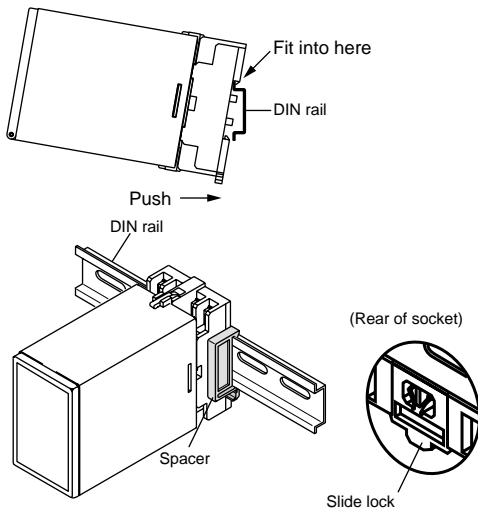

1.3 Using Ducts

Wiring ducts should be installed at least 30 mm away from the top or bottom of the main unit.

2. INSTALLATION LOCATIONS

- Avoid the following environments for installation locations: Areas with vibration, corrosive gases, dust, water, oil, solvents, direct sunlight, radiation, a strong electric field, and/or a strong magnetic field
Installation altitude: 2000 m or less above sea level.
- If there is any risk of a surge being induced into the power line and/or signal lines due to lightning or other factors, a dedicated lightning arrester should be used as protection for both this converter and a field-installed device.
- Operating temperature/humidity range: 0 to 50°C/5 to 90%RH (no condensation)

3. EXTERNAL WIRING



WARNING

To avoid the risk of an electric shock, turn off the power supply and use a tester or similar device to ensure that no power is supplied to a cable to be connected, before carrying out wiring work.

Wires are connected to the terminals of the converter's socket. M3.5 screw terminals are provided for the connection of external signals. Attach a crimp-on lug to each wire for connection to the terminals.

- Recommended cables: A nominal cross-sectional area of 0.5 mm² or thicker for signal cables, and that of 1.25 mm² or thicker for power cables.

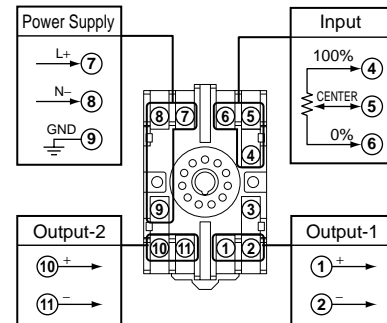

IMPORTANT

- **The power line and input/output signal lines should be installed away from noise-generating sources. Other wise accuracy cannot be guaranteed.**
- **The grounding resistance must be 100 Ω (JIS Class D grounding). The length and thickness of the grounding cable should be as short and thick as possible. Directly connect the lead from the ground terminal (terminal no. 9) of the product to the ground. Do not carry out daisy-chained inter-ground terminal wiring.**
- **Use of the product ignoring the specifications may cause overheating or damage. Before turning on the power, ensure the following:**
 - Power supply voltage and input signal value applied to the product should meet the required specifications.**
 - The external wiring to the terminals and wiring to ground are as specifications.**
- **Do not operate the product in the presence of flammable or explosive gases or vapors. To do so is highly dangerous.**
- **The product is sensitive to static electricity; exercise care in operating it. Before you operate the product, touch a nearby metal part to discharge static electricity.**



NOTE

Be sure to set the input range before using the product (see Chapters 4 and 5 in this manual).

Power Supply and Isoiaon

Power supply rated voltage:

15-40 V DC \approx or 100-240 V AC/DC \approx 50/60 Hz

Power supply input voltage:

15-40 V DC \approx ($\pm 20\%$) or 100-240 V AC/DC \approx ($-15, +20\%$) 50/60 Hz

Power consumption:

24 V DC 2.3 W, 110 V DC 2.2 W

100 V AC 4.6 VA, 200 V AC 6.4 VA

Insulation resistance:

100 M Ω at 500 V DC between input, output, power supply, and grounding terminals mutually.

Withstand voltage:

2000 V AC for 1 minute between input, output, power supply and grounding terminals mutually.

1000 V AC for 1 minute between output-1 and output-2 terminals.

4. DESCRIPTION OF FRONT PANEL

The figure below shows the converter of which the front panel cover is open.

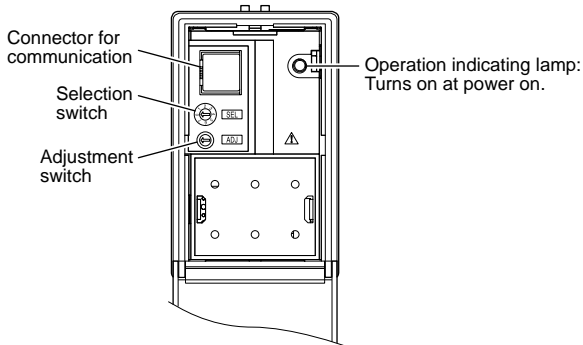

4.1 Operation Indicating Lamp

The operation indicating lamp shows the operation status, abnormalities in a setting, and adjustment operation status by the adjustment switch on the front panel.

(1) When the lamp is lit:

Power is turned on and the converter is in the normal status provided that the selection switch is set to the position "0."

(2) When the lamp is blinking rapidly:

The lamp repeats the rapid blinking until the internal processing is completed during output adjustment and the input range setting by the adjustment switch.

(3) When the lamp is blinking slowly:

The lamp repeats the slow blinking until the converter regains its normal status when the following abnormalities occur.

- Abnormalities in a parameter setting
- The selection switch is set to the positions other than "0."
- Input is outside of the range of -10 to 110% .

4.2 Connector for Communication

Use the connector for communication when setting the parameters using a PC (VJ77 Parameter Setting Tool) or the Handy Terminal.

< How to connect with the setting tool >

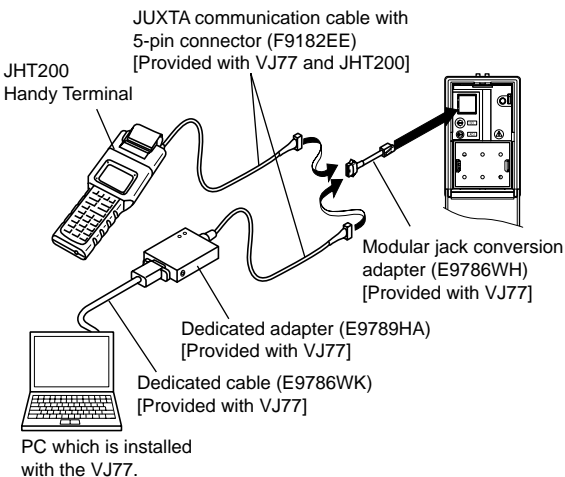

*: Use the VJ77 of version R1.04 or later.

4.3 Selection Switch and Adjustment Switch

The following adjustments can be performed using the switches on the front panel (selection switch and adjustment switch) without the dedicated setting tool (refer to "4.2 Connector for Communication").

The adjusted value is saved about 1 second after operating the adjustment switch. Also when the rotation direction of the adjustment switch is changed, the adjusted value becomes effective about 1 second after the change.

Position of selection switch	Item to be adjusted
0	No function
1	Output-1 zero adjustment
2	Output-1 span adjustment
3	Output-2 zero adjustment
4	Output-2 span adjustment
5	Input low range setting
6	Input high range setting

Rotation direction of adjustment switch	Adjustment operation
Clockwise	Increase of output adjusted value and setting of input low/high range
Counterclockwise	Decrease of output adjusted value and reset of input set value

[Adjusted volume by the adjustment switch]

One click changes about 0.005% of output range.

4.3.1 Adjusting Output Using the Switches on the Front Panel

(1) Output-1 zero adjustment

Apply the 0% input signal. Turn the selection switch to "1." Then turn the adjustment switch clockwise to increase the output, or turn it counterclockwise to decrease the output.

(2) Output-1 span adjustment

Apply the 100% input signal. Turn the selection switch to "2." Then turn the adjustment switch clockwise to increase the output, or turn it counterclockwise to decrease the output.

Output-2 can be adjusted by the same operation as the above.

(3) Output-2 zero adjustment

Apply the 0% input signal. Turn the selection switch to "3." Use the adjustment switch for adjustment.

(4) Output-2 span adjustment

Apply the 100% input signal. Turn the selection switch to "4." Use the adjustment switch for adjustment.

4.3.2 Setting Inpt Range Using the Switches on the Front Panel



NOTE

- **Set the burnout action before setting the input range. Changing the burnout action setting resets the input range.**
- **Turn the adjustment switch counterclockwise to reset the set value before setting the input range.**

(1) Resetting the input range

Turn the selection switch to "5" or "6", and turn the adjustment switch counterclockwise. Then the input low range or input high range are reset.

(2) Setting the input low range

Apply the stable signal equivalent to 0% input from the connected potentiometer. Turn the selection switch to "5", and turn the adjustment switch clockwise. Then the input low range is set after one second automatically.

(3) Setting the input high range

Apply the stable signal equivalent to 100% input from the connected potentiometer. Turn the selection switch to "6", and turn the adjustment switch clockwise. Then the input high range is set after one second automatically.



NOTE

- **Be sure to set the selection switch back to the position "0" after each adjustment. Otherwise it may cause an incorrect operation or malfunction because the positions other than "0" are adjustment modes.**
- **When the selection switch is set to the positions other than "0", the setting tool can not be used for the setting.**

5. SETTING PARAMETERS

Set the parameters using a PC (VJ77 Parameter Setting Tool) or the Handy Terminal. Refer to "6. List of Parameters" in this manual and the User's Manual for VJ77 PC-based Parameters Setting Tool (IM 77J01J77-01E) or the User's Manual for JHT200 Handy Terminal (IM JF81-02E). Parameters are indicated inside the [].

5.1 Setting Burnout Action

Set the burnout action in [D43:BURN OUT].
Set "OFF", "UP", or "DOWN".



NOTE

- **Set the burnout action before setting the input range. Changing the burnout action setting resets the input range.**
- **Turn the adjustment switch counterclockwise to reset the set value before setting the input range.**

5.2 Setting Input Range

Set the input low range in [P16:IN1 LOW RNG], and input high range in [P17:IN1 HIGH RNG].

- (1) Resetting the input range
Select and set "RESET" in [P16:IN1 LOW RNG] or [P17:IN1 HIGH RNG]. Then the input low range or input high range are reset.
- (2) Setting the input low range
Apply the stable signal equivalent to 0% input from the connected potentiometer. Select and set "EXECUTE" in [P16:IN1 LOW RNG]. Then the input low range is set automatically.
- (3) Setting the input high range
Apply the stable signal equivalent to 100% input from the connected potentiometer. Select and set "EXECUTE" in [P17:IN1 HIGH RNG]. Then the input high range is set automatically.

5.3 Setting Output-1 Range

Set the output-1 range 0% in [D38:OUT1L_RNG], and the output-1 range 100% in [D39:OUT1H_RNG].



NOTE

Changing the output-1 range resets the adjusted value.

6. LIST OF PARAMETERS

Parameter Display		Item
	MODEL	Model
	TAG NO	Tag number
	SELF CHK	Self-check result
A	DISPLAY1	Display1
A07	OUTPUT1	Output-1
A08	OUTPUT2	Output-2
A54	STATUS	Status *1
A56	REV NO	REV No.
A58	MENU REV	MENU REV
A60	SELF CHK	Self-check result
B	DISPLAY2	Display2
B07	OUTPUT1	Output-1
B08	OUTPUT2	Output-2
B60	SELF CHK	Self-check result
D	SET (I/O)	Setting (I/O)
D01	TAG NO.1	Tag number-1
D02	TAG NO.2	Tag number-2
D03	COMMENT1	Comment-1
D04	COMMENT2	Comment-2
D38	OUT1 L_RNG	Output-1 low range
D39	OUT1 H_RNG	Output-1 high range
D40	OUT2 L_RNG	Output-2 low range *2
D41	OUT2 H_RNG	Output-2 high range *2
D43	BURN OUT	Burnout
D49	OUT1 DR	Direction of output-1 action
D50	OUT2 DR	Direction of output-2 action
D60	SELF CHK	Self-check result
P	ADJUST	Adjustment
P16	IN1 LOW RNG	Setting of input-1 low range
P17	IN1 HIGH RNG	Setting of input-1 high range
P26	OUT1ZERO ADJ	Output-1 zero adjustment
P27	OUT1SPAN ADJ	Output-1 span adjustment
P28	OUT2ZERO ADJ	Output-2 zero adjustment
P29	OUT2SPAN ADJ	Output-2 span adjustment
P60	SELF CHK	Self-check result
Q	TEST	Test
Q03	OUT1 TEST	Forced output-1
Q04	OUT2 TEST	Forced output-2
Q60	SELF CHK	Self-check result

*1 The displayed status is to let the service staff know the past records of the product.

*2 The parameters are the items to be set at the factory.

7. MAINTENANCE

The product starts running immediately when the power is turned on; however, it needs 10 to 15 minutes of warm-up before it meets the specified performance.

7.1 Calibration Apparatus

- Two 6-dial variable resistor (Yokogawa M&C 279301 or the equivalent)
- A digital multimeter (Yokogawa 7561 or the equivalent)
- A precision resistor of $250\ \Omega \pm 0.01\%$, 1 W
- A setting tool for adjustment
(Refer to “4.2 Connector for Communication” in this manual.)

7.2 Calibration Procedure

- (1) Connect the instruments as shown below. First adjust the output-1 signal and then the output-2 signal.
 - (2) Operate the variable resistor corresponding to the specifications of the potentiometer to be combined (overall resistance, resistance of 0% and 100%). Change the values of R1 and R2 maintaining the overall resistance constantly, and apply the input signal equivalent to 0, 25, 50, 75 and 100% of the input span to the converter.
 - (3) Check to see the corresponding output voltages are 0, 25, 50, 75, and 100% respectively and within the specified accuracy rating.
“R” is used for current output.
- Use the setting tool (VJ77 Parameter Setting Tool or JHT200 Handy Terminal) to adjust the input/output signals, or using the selection switch and adjustment switch on the front panel.

Input Adjustment Procedure

Refer to “4.3.2 Setting Input Range Using the Switches on the Front Panel” and “5.2 Setting Input Range” for the input adjustment.



NOTE

It is recommended that you use the potentiometer actually used for inputs in the field when the input adjustment is performed.

Because some differences occur compared with the test inputs using the 6-dial variable resistor owing to the influence of the tolerance of potentiometer resistance and wiring resistance.

The accuracy may not be maintained if you use the potentiometer actually used for inputs after performing the input adjustment by test inputs.

Output Adjustment Procedure

- (1) When adjusting 0% value of output-1, call the adjustment item (P: ADJUST) to select P26: OUT1ZERO ADJ.
 - (2) If it slips out to (+) side, set (-) value equivalent to slipout; if slips out to (-) side, set (+) value equivalent to slipout.
- *: The 100% value of output-1 and 0% value and 100% value of output-2 can be adjusted by the same operation as the above.

For adjustment using a setting tool, refer to the User's Manual for each setting tool and “6. List of Parameters” in this manual.

For adjustment using the switches on the front panel, refer to “4.3 Selection Switch and Adjustment Switch.”

User's Manual for VJ77 [Document No.: IM 77J01J77-01E]; however, use the VJ77 of version R1.04 or later.

User's Manual for JHT200 [Document No.: IM JF81-02E]

